



Suspension Systems

The suspension systems incorporated into Dexter axles are designed to provide the trailer owner three basic functions:

1. Attach the axle to the trailer
2. Dampen the effects of road shock
3. Cushion the cargo or load

All Dexter suspension systems are available in single and multiple axle configurations. The three types most commonly available are double eye leaf spring, slipper spring and Torflex®.

Double Eye Leaf Springs

Double eye springs have eyes formed in each end of the spring with anti-friction bushings fitted for wear resistance. The springs are held to the axle tube using a system of U-bolts and clamp plates and are attached to the trailer as shown.

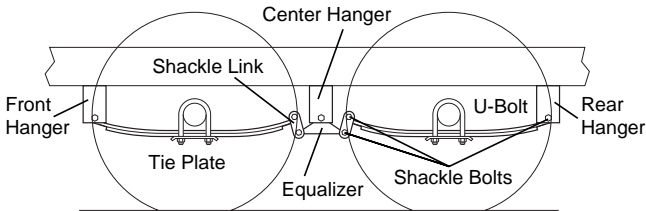

Underslung Shown

Articulation of this suspension occurs when the spring becomes loaded and consequently lengthens. The double pivot action of the shackle links accommodates this articulation and allows the system to move freely.

In multiple axle installations, the action is the same with the additional movement of the equalizer assembly. This serves to transfer instantaneous loads from one axle to another in an effort to “equalize” the load between the axles.

Grease Lubricated Suspension Bushings

Dexter Axle offers an optional heavy duty attaching parts kit for double eye leaf spring suspensions up to 7,000 lb. axle capacity. The kit contains extra heavy shackle links, bronze bushings for the spring eyes and suspension bolts and equalizers equipped with grease fittings to provide a convenient means to lubricate all the pivot points. For availability, contact your nearest Dexter Axle facility or visit us on-line at www.dexteraxle.com for a complete listing of genuine repair parts.

Slipper Leaf Springs

Slipper springs have an eye formed in one end only with the other end formed into a reverse curve. The attachment of these springs is as follows:

1. The front eye is attached directly into the front hanger with a bolt and nut.
2. The rear end of the spring is captured in the rear hanger or equalizer with a “keeper bolt” that prevents the spring from coming out when the trailer is jacked up for service.

The articulation of this suspension occurs when the rear end of each slipper spring slides against the wear surfaces provided in the rear hangers or equalizers. This suspension is also available in single and multiple axle configurations.

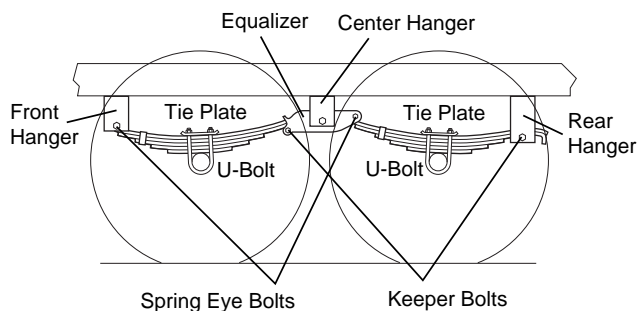

Overslung Shown





Inspection and Replacement

All the components of your suspension system should be visually inspected at least every 6,000 miles for signs of excess wear, elongation of bolt holes, and loosening of fasteners. Whenever loose or replaced, the fasteners in your suspension system should be torqued as detailed in the charts below.

CAUTION

You must follow the maintenance procedures to prevent damage to important structural components. Damage to certain structural components such as wheel bearings can cause the wheel to come off of the axle. Loss of a wheel end while the trailer is moving can cause you to lose control and lead to an accident, which can result in serious injury or death.

Suspension Fastener Torque Values

Item	Torque (lbs.-ft.)	
	Min	Max
$\frac{3}{8}$ " U-Bolt	30	50
$\frac{7}{16}$ " U-Bolt	45	70
$\frac{1}{2}$ " U-Bolt	45	70

Non shoulder type with $\frac{9}{16}$ " threads

Shackle Bolt	Snug fit only. Parts must rotate freely. Locking nuts or cotter pins are provided to retain nut-bolt assembly.	
Spring Eye Bolt		
Equalizer Bolt		

Shoulder Type 30 50

Shackle Bolt with $\frac{7}{16}$ " threads

Worn spring eye bushings, sagging springs, or broken springs should be replaced using the following method.

1. Support the trailer with the wheels just off the ground.

CAUTION

Do not lift or support the trailer on any part of the axle or suspension system. Never go under any trailer unless it is properly supported on jack stands which have been rated for the load. Improperly supported vehicles can fall unexpectedly and cause serious injury or death.

2. After the unit is properly supported place a suitable block under the axle tube near the end to be repaired. This block is to support the weight of the axle only, so that suspension COMPONENTS can be removed.
3. Disassemble the U-bolts, nuts, and tie plates.
4. Remove the spring eye bolts and remove the spring and place on a suitable work surface.
5. If the spring eye bushings are to be replaced, drive out the old bushing using a suitable drift punch.

CAUTION

Be sure to wear safety glasses when removing or installing force fitted parts. Failure to comply may result in serious injury.

6. Drive the new bushing into the spring eye using a piloted drift punch or a close fitting bolt inserted through the bushing.
7. Reinstall repaired or replaced components in reverse order.

Note: *For multiple axle units, the weight of each axle must be supported as outlined in Step 2 before disassembly of any component of the suspension system.*

If the equalizer or equalizer bushings must be replaced, follow the instructions above for lifting and supporting the trailer unit and then proceed as follows:





1. With both axles blocked up, remove the spring eye bolt, shackle bolt, and equalizer bolt from the equalizer to be repaired or replaced.
2. Take the equalizer to suitable work surface and remove the worn bushings using a suitable drift punch.
3. Drive the new bushings into place using a piloted drift punch or a close fitting bolt through the bushing.
4. Reassemble in reverse order.

CAUTION

Be sure to wear safety glasses when removing or installing force fitted parts. Failure to comply may result in serious injury.

All of the pivot points on your standard suspension system have been fitted with anti-friction bearing materials which do not require routine lubrication. When otherwise servicing the unit, these pivot points may be lubricated if you so desire. If your trailer has been fitted with the Heavy Duty Attaching Parts Kit, you should lubricate periodically to ensure long component life.

Torflex® Suspension

The TORFLEX® suspension system is a torsion arm type suspension which is completely self contained within the axle tube. It attaches directly to the trailer frame using brackets which are an integral part of the axle assembly. The TORFLEX® axle provides improved suspension characteristics relative to leaf spring axles through the unique arrangement of a steel torsion bar

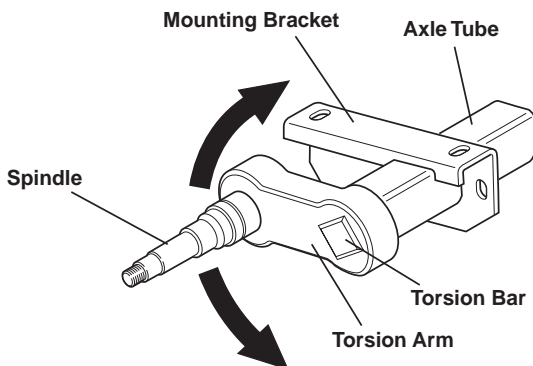

surrounded by four natural rubber cords encased in the main structural member of the axle beam.

The wheel/hub spindle is attached to a lever, called the torsion arm, which is fastened to the rubber encased bar. As load is applied, the bar rotates causing a rolling/compressive resistance in the rubber cords. This action provides the same functions as conventional sprung axles with several operating advantages including independent suspension.

Except for periodic inspection of the fasteners used to attach the TORFLEX® axle to the vehicle frame, no other suspension maintenance is required on TORFLEX® axles. They are, of course, subject to the maintenance and inspection procedures regarding brakes, hubs, bearings, seals, wheels, and tires as outlined in this manual.

CAUTION

DO NOT WELD ON THE TORFLEX® BEAM. It has rubber cords inside and the heat generated by welding could damage the cord.

Airflex™ Suspension

The Dexter **AIRFLEX™** suspension is a unique combination of Torflex® axle and conventional air suspension technology. This low maintenance suspension system carries the load on a cushion of air, usually supplied by an on-board compressor and storage tank. A load leveling valve maintains a constant ride height, regardless of load. As load is added to the trailer, the valve will automatically signal the compressor to supply more air. As loads are removed, the same valve will exhaust air to maintain the same height and ride characteristics.

The **AIRFLEX™** suspension can be supplied with a dump valve which allows the trailer to be lowered several inches to facilitate loading or leveling. Once loaded, the valve is reversed and the system is pressurized to raise the trailer back up to normal running height.





Axle Adjustment

1. Support the trailer frame on a level surface. If the wheels are already mounted, make sure they are clear of the ground. If the air actuation system has been installed, make sure the air pressure in the air bags is bled off before lifting the trailer. **CAUTION: Lifting the trailer with air system pressurized will overextend the air bags and can result in damage to the air bags.**

CAUTION

Do not lift or support the trailer on any part of the axle or suspension system. Never go under any trailer unless it is properly supported on jack stands which have been rated for the load. Improperly supported vehicles can fall unexpectedly and cause serious injury or death.

2. Measure from king pin to spindle center on each side. To simplify this process, plumb lines may be dropped from the king pin and from the centerline of each spindle end. Measurements "A" and "B" can then be taped on the floor to eliminate any miss measurement due to sagging of the tape long measurements. Compare A and B measurements (see Figure 1).
3. Loosen all the U-bolt nuts slightly and move the axle assembly with the adjusting screws, located on the front and rear of the axle seat. Move front axle to correct alignment position based on previous findings of A and B measurements. Make sure both front and rear adjusting screws are snug after axle is realigned. Then, retighten the U-bolt nuts to 100 to 120 lb ft.

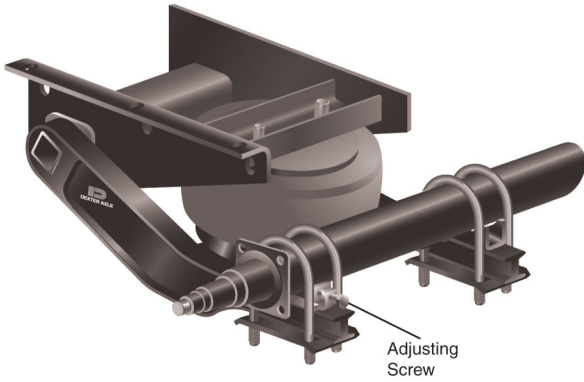

4. Re-measure A and B, as before, to assure that "A" and "B" dimensions are within $1/16$ " of each other. If dimensions are not to specification, then repeat adjustment procedure.

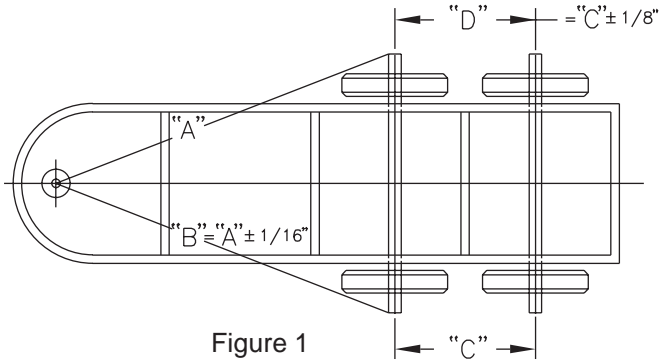

Figure 1



Tandem Axle Adjustment

1. Adjust the second axle using it's left hand spring seat adjusters to assure distances "C" and "D" are within tolerance.
2. Measure the distances "C" and "D" between the front and rear tandem axles. These distances must be within 1/8" of each other.
3. After alignment is completed make sure all nuts and bolts are tightened to their respective torque values.
4. The limits of 1/16" and 1/8" appear very small in comparison to the overall dimensions of the vehicle but they are recognized as the maximum permissible limit of misalignment. Also, the relatively small size of those limits makes accurate measurements important.