



# ***Eliminator Vented Disc Brakes Owners Manual***



***TIE DOWN ENGINEERING, Inc.***  
***5901 Wheaton Drive, Atlanta, GA 30336***  
***www.tiedown.com***

***(404) 344-0000 • Fax (404) 349-0401***

© 2005 TIE DOWN ENGINEERING, INC. ALL RIGHTS RESERVED

# Vented Rotor Disc Brakes, w/Aluminum Caliper

Read your trailer manufacturer's operating manual and follow the towing vehicle's guidelines for towing capability, hitch requirements and other towing information.

Congratulations on your decision to have Tie Down Engineering vented rotor disc brakes with aluminum caliper installed on your trailer. Disc brakes have many advantages over drum brakes. These include:

- Greater fade resistance
- Self adjusting
- Greater stopping power
- Self cleaning
- Less maintenance
- Easy visual inspection without removing any parts

Tie Down Engineering vented rotor disc brakes with aluminum calipers have many exclusive features not found on automotive type brakes modified for trailer use. Please see our web site at [tiedown.com](http://tiedown.com) for further information on features and benefits.

Vented rotor disc brakes are designed to activate when the vehicle's brakes are applied. As the vehicle stops or slows, the momentum of the trailer pushes forward developing pressure in the actuator (master cylinder), used to apply pressure to the brakes.

## Operating Information

Read and understand the towing information for your trailer and actuator.

Check your trailer frequently for any leaks in the hydraulic system, which includes the actuator, brake lines and brakes.

The brake rotors are made of steel and will show surface rust on the braking surface when not used for a week or more. Normal use will wipe the rust off of the rotor surface. If the trailer is used in salt water, it is recommended that you rinse off the brakes with fresh water after each use to reduce the effects of saltwater corrosion.

Your trailer should tow easily. Disc brakes operate at a higher temperature than drum brakes. This is normal and is very similar to the way disc brakes operate on your vehicle. If for any reason your trailer does not tow easily or wants to veer to one side, stop and investigate immediately and solve the problem.

Towing a trailer (even a trailer with brakes) puts an added load on the tow vehicle's handling and braking capabilities. Do not follow too closely; you will need extra distance to maneuver and to stop.

Towing downhill puts added stress on both the tow vehicle and the trailer. Slow down before you start on an incline and maintain a controlled downhill speed with repeated application of brakes followed by a cooling period when brakes are not applied. It is very important to start off with a slow speed and maintain it rather than trying to slow down from a higher speed. Should you feel the brakes on the trailer or tow vehicle are running hot or showing signs of fade, stop immediately on the side of the road and allow the brakes to cool before resuming your trip.

Should you feel the tow vehicle and trailer brakes are not working as they should; have the tow vehicle and trailer inspected. Make sure your trailer's GVW is within the tow vehicles capacity. If your trailer has multiple axles, verify that the GVW of the trailer does not exceed the capacity of the brakes, which is 3750 lbs on 10-inch (5 lug) brakes and 6000 lbs on 12-inch (6 lug) brakes, per axle. Some states require brakes on all axles. Check with your state laws and the state laws of where you will be using your trailer.

After long trips or downhill towing, your brakes could be very hot and it is a good idea to let them cool down before submerging in cold water. The change in temperature of very hot brakes submerged in water creates additional stress on the parts and could cause damage to your brakes.



# Vented Rotor Disc Brakes, w/Aluminum Caliper

Pads must be replaced when the friction material is 3/32" or less. Original Tie Down Engineering brake pads have a GalvX coated backing plate that aids in corrosion resistance. Replacement pads can also be purchased at most auto parts stores. Use NAPA #TS-7192-M or IBN # 289 and MXD289 (1990 Chevrolet Cavalier front brakes).

Use DOT 3 hydraulic fluid only. **DO NOT USE SILICONE BASED BRAKE FLUID.**

When backing a trailer with disc brakes, you must have a lockout lever or preferably an electrically operated solenoid to stop brake pressure to the disc brakes. The solenoid is mounted at the rear of the actuator, between the master cylinder and brake line. It has a wire connected to your back up lights to stop or redirect the fluid to keep the brakes from operating.

## Hub Removal/Remounting, replacing brake pads

Removing the brake for inspection or maintenance should be done in a safe location away from moving vehicles.

### Replace Brake Pads

1. Elevate the trailer using the manufacturers instructions. Always use jack stands for support. Do not depend on a jack to support the trailer. Block wheels to keep trailer from rolling.
2. Remove the tire/wheel assembly. Inspect the rotor surface. Check for excessive wear or grooves that may affect braking. Original rotor thickness is .939 in.; minimum thickness is .85 in. or 21.6 mm.
3. Inspect brake pads. Minimum thickness is 3/32". Pads should be replaced if below this width.
4. Remove the caliper by unscrewing the slider pins from the mounting bracket. Be careful to hold the caliper in place so that it does not fall and pull on the brake hose. The inside pad is spring loaded in the caliper piston. Pry this pad out gently with a flat blade screwdriver. The outside pad is held in place with two metal tabs. Use a large pair of pliers to straighten the tabs to remove the outside pad.
5. Clean the rotor with a brake cleaning spray. Replace brake pads in reverse order. The tabs should only be bent enough to hold the pad in place. Do not bend tab to far or the pad will not seat correctly. Outside pad should be able to "wiggle" after tab is bent.
6. Clean threads of slider bolts and apply a coating of Loc-tite or similar brand of thread lock. Tighten bolts to 40 ft lbs. **DO NOT REASSEMBLE WITHOUT APPLYING LOC-TITE TO THE THREADS. BOLTS COULD BACK OUT AND CAUSE PERMANENT DAMAGE TO YOUR BRAKES AND TRAILER.**

### Removing Hub/Rotor

1. If your axle has an integral style rotor, hub and rotor is one piece, and will come off as one.
2. If you have a cap style rotor, the rotor will be removed after the wheel and caliper is removed. The hub will come off separate.
3. Elevate the trailer using the manufacturers instructions. Always use jack for support. Do not depend on a jack to support the trailer. Block wheels to keep trailer from rolling.
4. Remove the tire/wheel assembly.
5. Remove the caliper by unscrewing the slider pins from the mounting bracket. Be careful to hold the caliper in place so that it does not fall and pull on the brake hose. Support the caliper so that it does not "hang" from the brake line.
6. Remove the grease cap from the hub by prying around the edge of the cap.
7. Bend the locking tang washer to the "free" position. If spindle is equipped with a cotter key, straighten cotter key to remove.



## Vented Rotor Disc Brakes, w/Aluminum Caliper

8. Remove the spindle nut in a counter clockwise direction and remove the spindle washer.
9. Remove the hub from the spindle. Be careful not to allow bearings to fall out of the hub.
10. Clean bearing and cup surfaces, repack with lithium marine grade grease.
11. Place hub on spindle in reverse order as listed above. Rotate the hub while tightening the spindle nut to approximately 50 ft lbs. This translates into full hand pressure with a 12" long set of pliers or 12" long wrench.
12. Loosen the spindle nut to remove the torque, do not rotate hub.
13. Finger tighten the spindle nut until snug, backing out only to line up the locking tang washer.
14. Bend the locking tang tab in place.
15. Replace rotor. Clean threads of slider bolts and apply a coating of Loc-tite or similar brand of thread lock. Tighten bolts to 20 ft lbs. **DO NOT REASSEMBLE WITHOUT APPLYING LOC-TITE TO THE THREADS. BOLTS COULD BACK OUT AND CAUSE PERMANENT DAMAGE TO YOUR BRAKES AND TRAILER.**
16. Replace cap. Install tire/wheel assembly, tighten wheel nuts to Trailer manufacturer specifications. Test wheel for excessive tightness or excessive play. readjust in necessary.
17. Road test vehicle in a safe place before traveling on main roads in traffic.

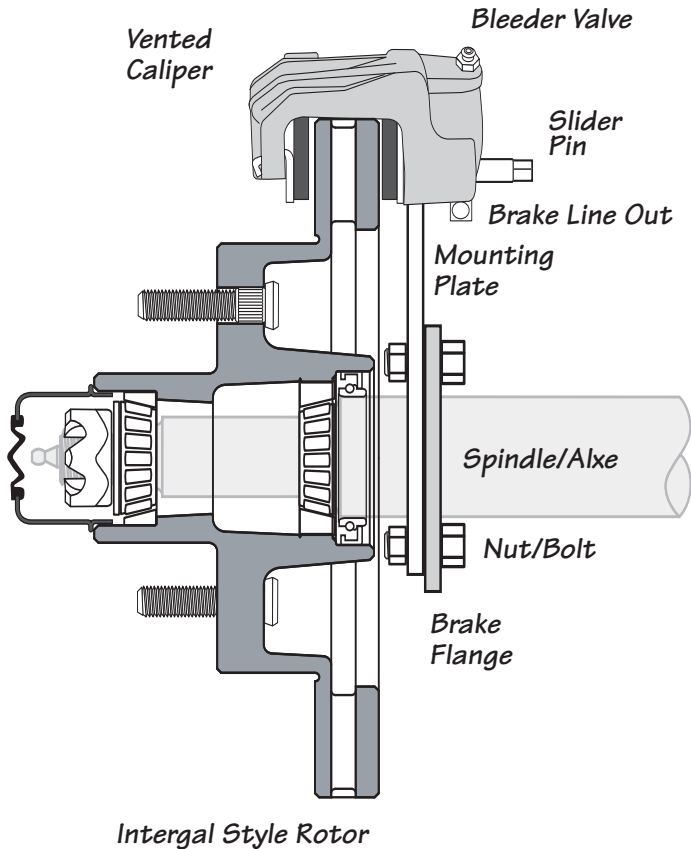

# Installation/Replacement Instructions for Vented Disc Brakes

1. On a bare axle attach mounting plate to the brake flanges on the axle. Preferred position is at "12:00" high or to the back side. Exact positioning will be determined by the brake flange. Use 7/16"x1-1/4" zinc hex bolts, lock nuts/washers and torque to 40 lbs.
2. If installation is on a completed trailer, remove tire/wheel. This would be a good time to repack wheel bearings and inspect the bearing and seals if it has not been done recently.
3. Install hub (use existing instruction on installing hubs).

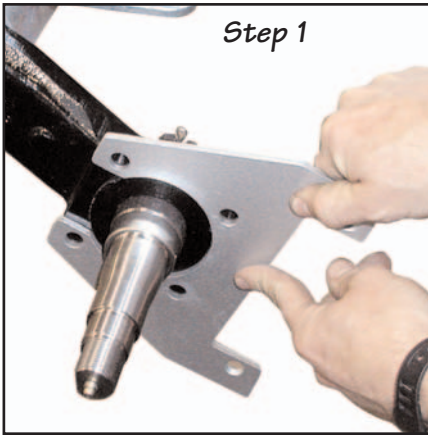

4. Place cap style rotor over hub. Make sure the hub face is clean with a smooth surface or:
  - 4a. If installing a integral or "one piece hub rotor", install rear bearing and seal. Grease bearings, install front bearings (use existing instruction on installing hubs).

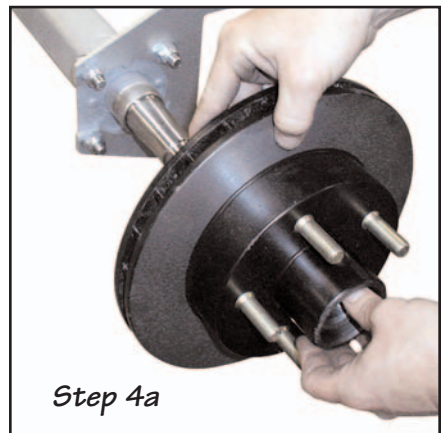

## Vented Disc Brakes

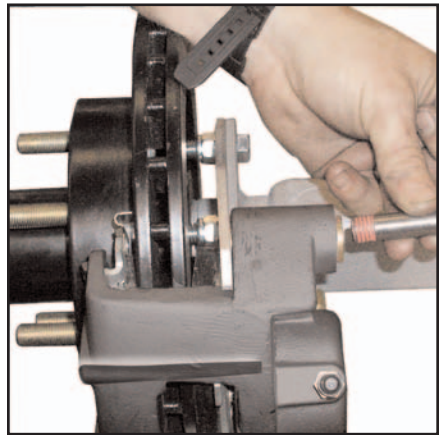
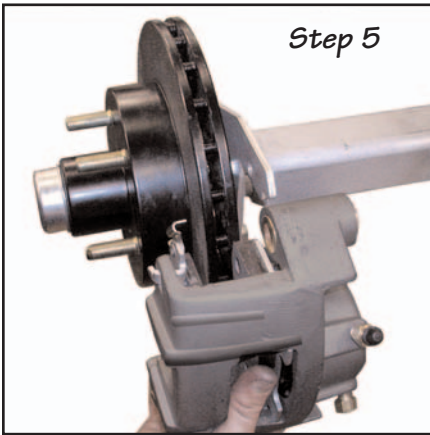

*Step 6*

5. Place caliper over rotor and mounting plate. A bleeder valve must be in the up position. Check both calipers for this position. Some calipers have two valves others have only one.
6. Insert slider pins thru backside of rotor into mounting plate. Use a 7/16" hex socket and tighten both pins to 40 ft. lbs. Check for binding, make sure rotor spins freely.
7. Connect brakes lines and bleed brakes before using.

**NOTE: Slider pins have a lock-thread coating. If pins are removed after step 6, the threads must be cleaned and a new coat of "permanent" Lock Tite® must be applied. Apply Lock Tite® to threads in mounting plate. Be careful not to get Lock Tite® on slider pins or bushings**



Item	Part #	Description
1	10010	Bronze Bushing
2	46304 46304A	Aluminum disc brake caliper for vented rotor - housing only Aluminum disc brake caliper for vented rotor, includes: 1,3,4,5,6, & 10
3	11246	Bleeder valves
4	11242	Inlet elbow for brake line
5	42080A	Caliper piston, stainless steel/aluminum
6	17472	Rubber boot, caliper
7	46246P	10" Cap style vented rotor, 5 hole, E-Coat finish
7	46246X	10" Cap style vented rotor, 5 hole, GalvX finish
7	46247P	12" Cap style vented rotor, 6 hole, E-Coat finish
7	46247X	12" Cap style vented rotor, 6 hole, GalvX finish
8	46430P	9.6" Integral vented rotor to fit 13" wheels, E-Coat finish
8	46430X	9.6" Integral vented rotor to fit 13" wheels, GalvX finish
9	46430TLP	9.6" Integral vented rotor to fit 13" wheels, with Turbo Lube, E-Coat finish
9	46430TLX	9.6" Integral vented rotor to fit 13" wheels, with Turbo Lube, GalvX finish
8	46245 P	10" Integral hub and vented rotor, 5 stud, E-Coat finish
8	46245X	10" Integral hub and vented rotor, 5 stud, GalvX finish
9	46244TLP	10" Integral hub vented rotor with Turbo Lube, E-Coat finish
9	46244X	10" Integral hub vented rotor with Turbo Lube, GalvX finish
8	46264P	12" Integral hub and vented rotor, 6 stud, E-Coat finish
8	46264X	12" Integral hub and vented rotor, 6 stud, GalvX finish
9	46264TLP	12" Integral hub vented rotor with Turbo Lube, E-Coat finish
9	46264TLX	12" Integral hub vented rotor with Turbo Lube, GalvX finish
10	11274 "inside" 11275 "outside"	Brake pads, or use NAPA #TS-7192-M (for 1990 Chevolet Cavalier) or: IBN #289 and MXD289
11	12114	7/16" Hex head slider pins, stainless steel (2 required)
12	44676G	Mounting bracket for 46430, Integral Rotor for 13" wheels, Galvanized finish
13	44479G	Mounting bracket for 46245 - 10" Integral Rotor, Galvanized finish
14	44480G	Mounting bracket for 46246 - 10" Cap Style Rotor, Galvanized finish
15	44478X	Mounting bracket for 12" Cap or Integral Style rotor, GalvX finish
These items are available at your local hardware store		Bolts for 10" mounting plate (4) 7/16" x 1-1/4" Grade 5 or better
		Nuts for 10" mounting plate (4) 7/16" nylock nut
		Bolts for 12" mounting plate (5) 3/8" x 1.5" Grade 5
		Nuts for 12" mounting plate (5) 3/8" nylock nut
		Bolts for 12" mounting plate for use with Eliminator 6000# Torsion Axles, tapped for 3/8"-24NF x 3/4"L Bolts Grade 5 or better (5), nuts not required

# Vented Rotor/Caliper Parts List

